

NB! Types of accessories must be selected according to a required fire class and must be approved by the manufacturer. Please contact your dealer for a list of approved accessories.

Position of accessories should be defined before production of the door. It is the responsibility of the customer, architect and dealer.

If your door is delivered without accessories, please follow the guidelines below:

Locks assembling

Adjustment

Intumescent cloth applied for lock case the whole length of the recess. Cut out in the intumescent cloth adjusted to necessary lock case holes.

Assembly

Slide in the intumescent cloth into recess in profile. Then assemble the lock case to fix the intumescent cloth in place.

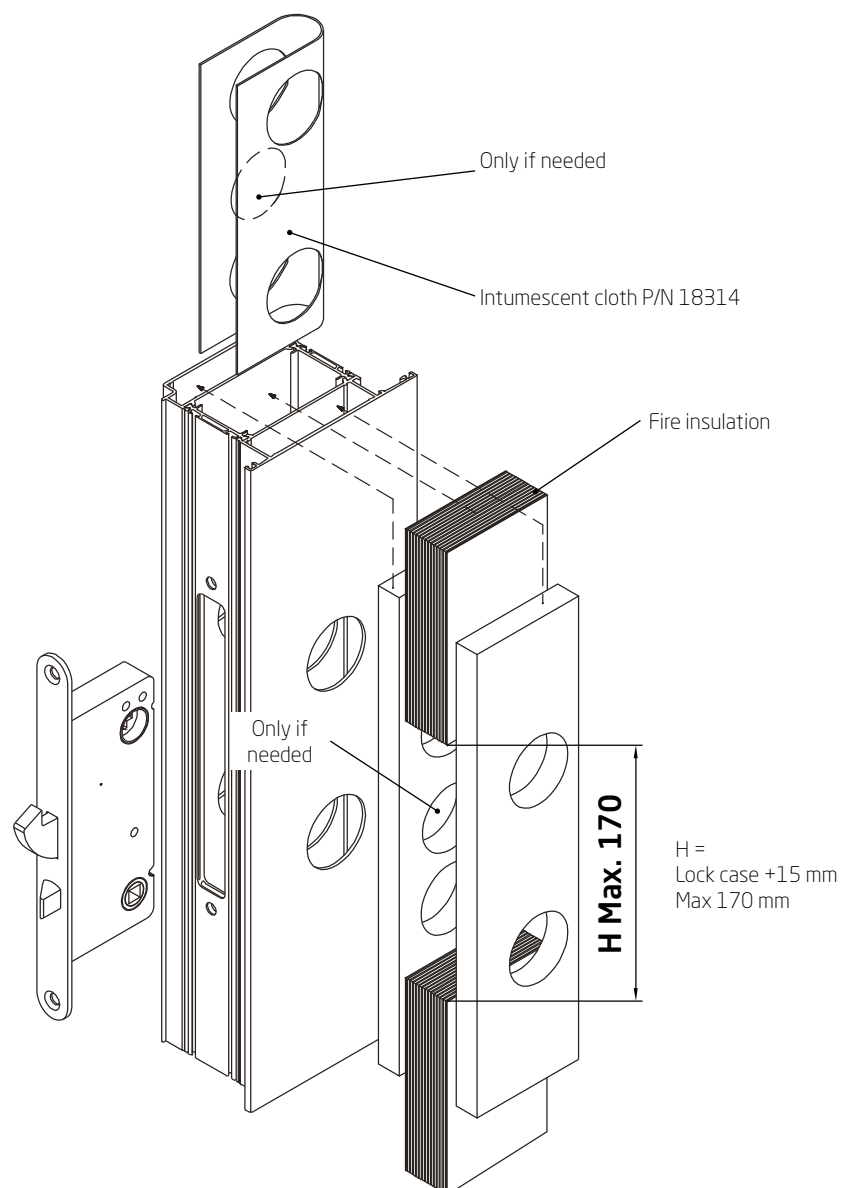

NB! Intumescent cloth is included in delivery. Fire insulation is cut and attached in the factory.

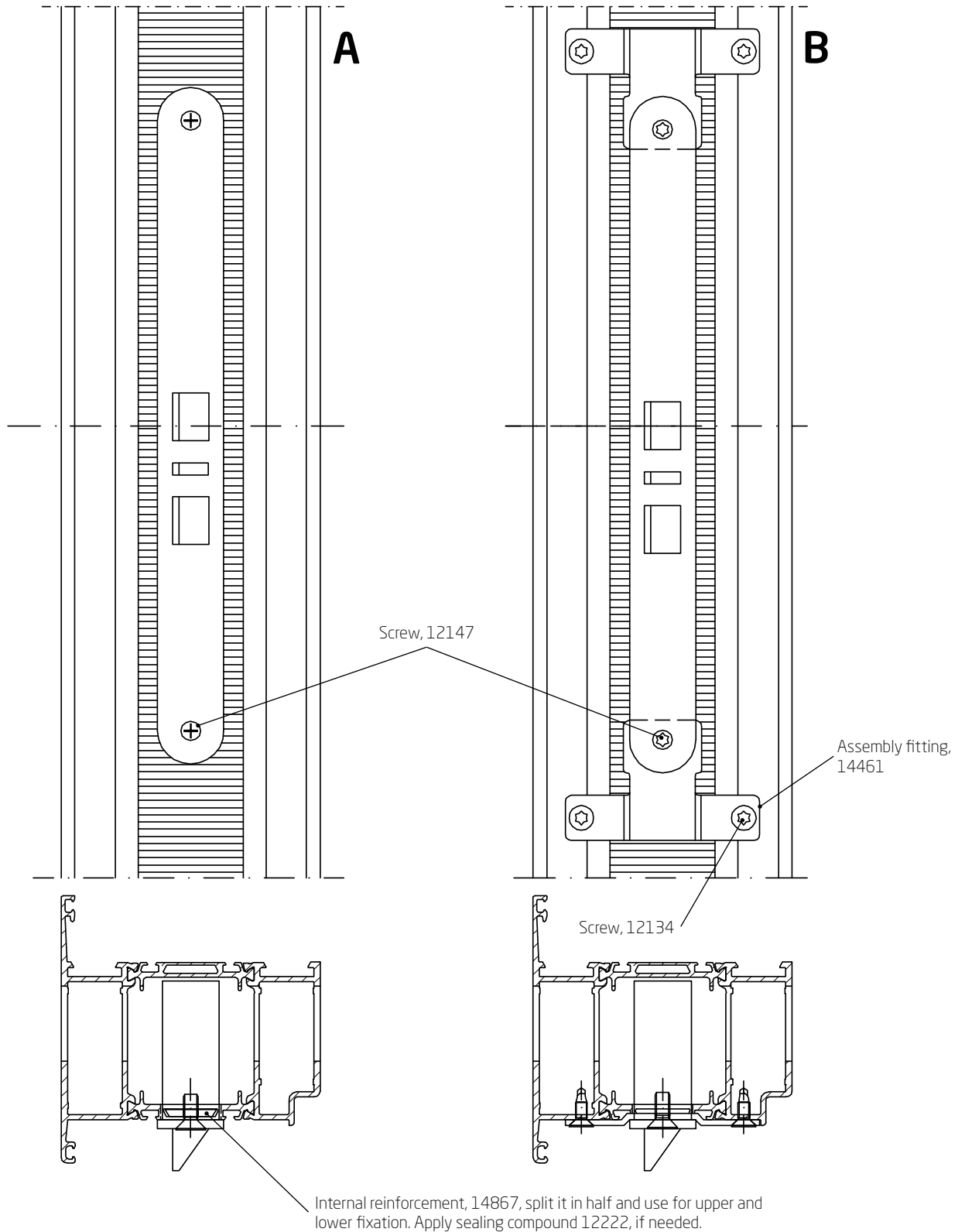

NB! Alternative A is factory standard. Reinforcement 14867 and screws are included in delivery.

Striking plates assembling:

Adjustment

Mount intumescent cloth along the whole length of the recess for electrical striker (no for mechanical strike plate).

Assembly

Slide in the intumescent cloth into recess in profile. Then assemble the electrical striker to fix the intumescent cloth in place.

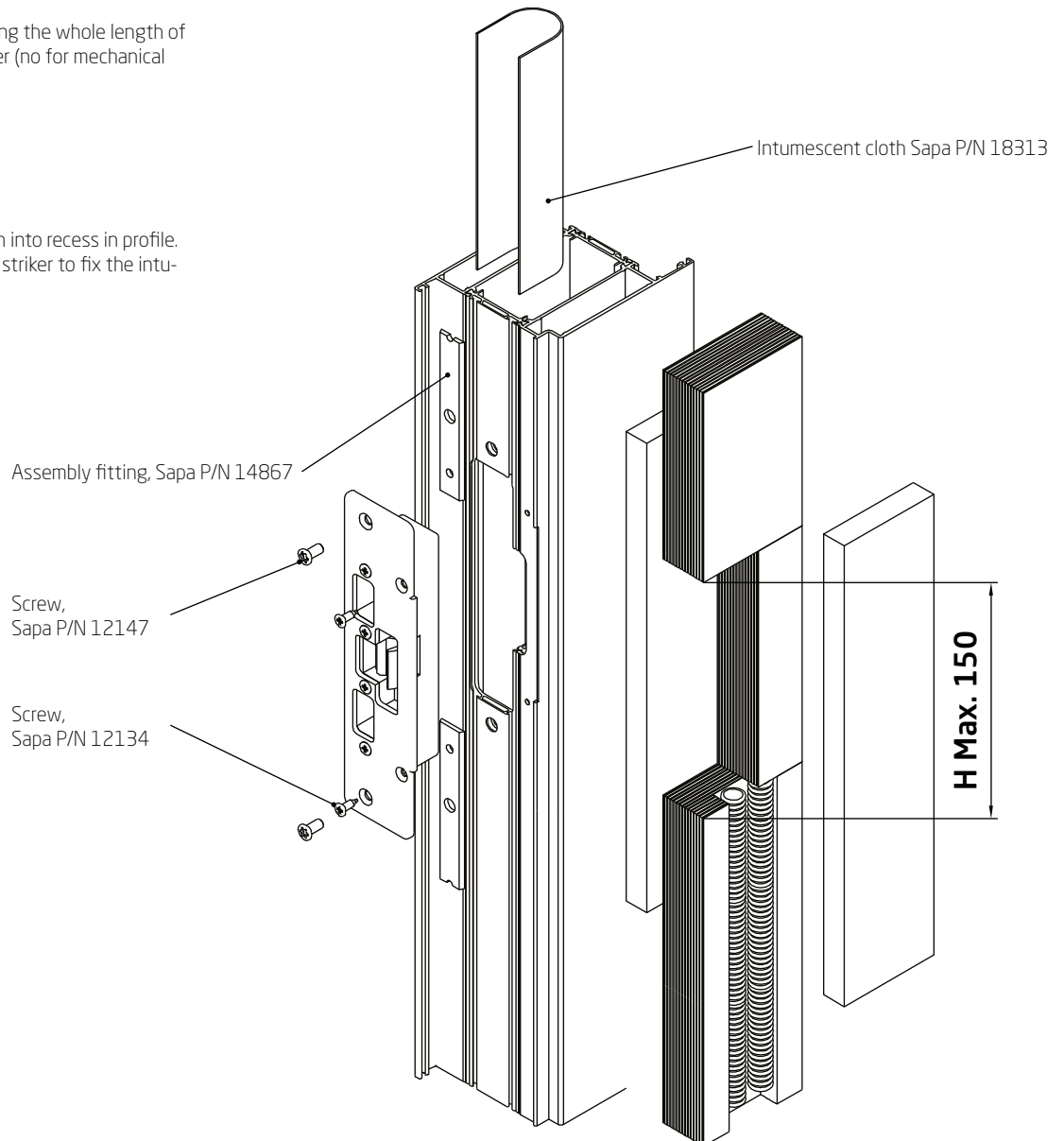

NB! Intumescent cloth is included in delivery. Fire insulation is cut and mounted in the factory. Assembly fitting P/N 14867 and screws are included in delivery.

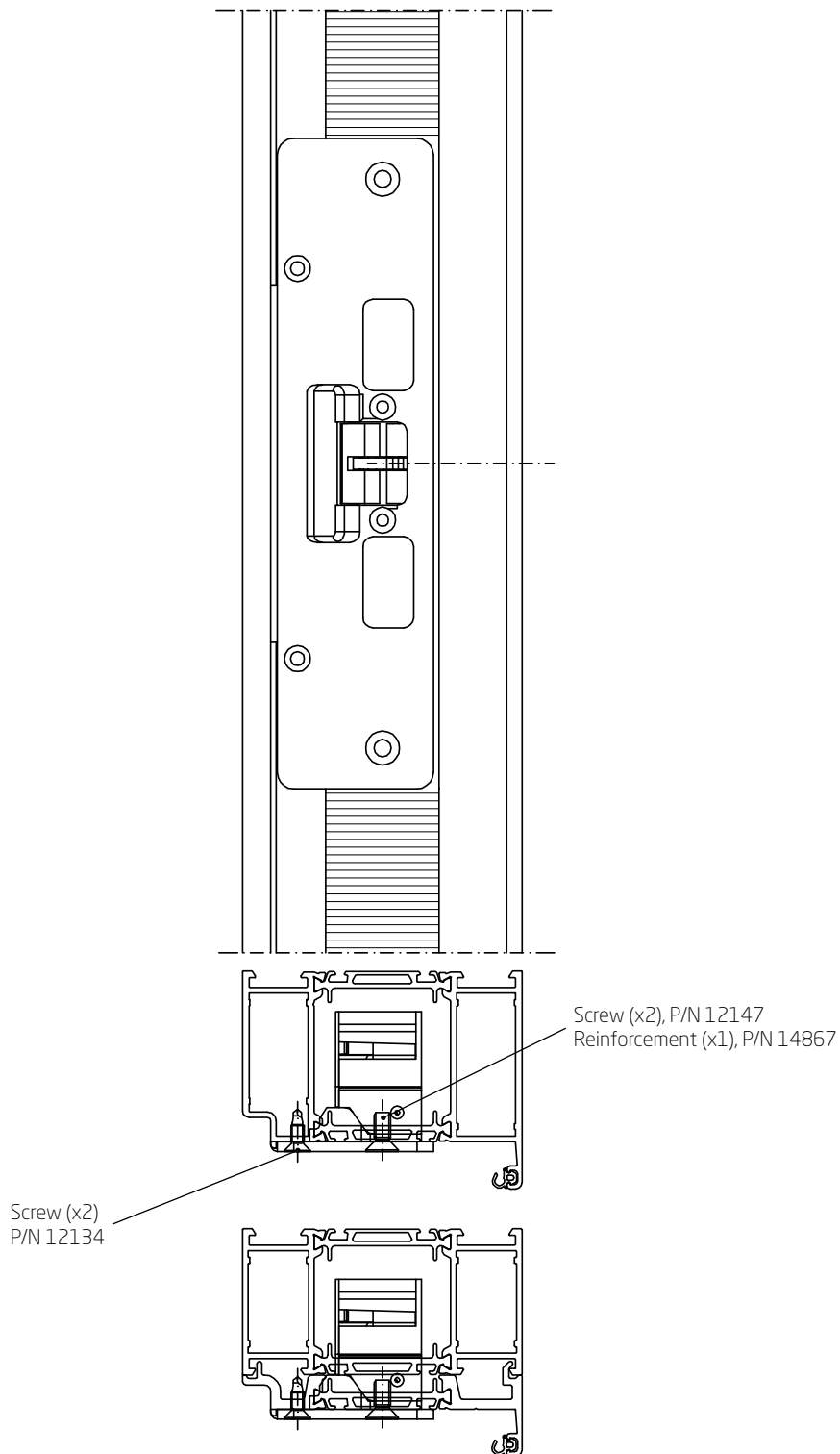

NB! Reinforcement 14867 and screws are included in delivery. Drawing refers to installation of ASSA 900-series electric striker (Faceplate ASSA 986). The same procedure is used for STEP 90/98 (Faceplate ST4086), STEP 92 (Faceplate ST9586), STEP 60 (Faceplate ST6586) series electric strikers.

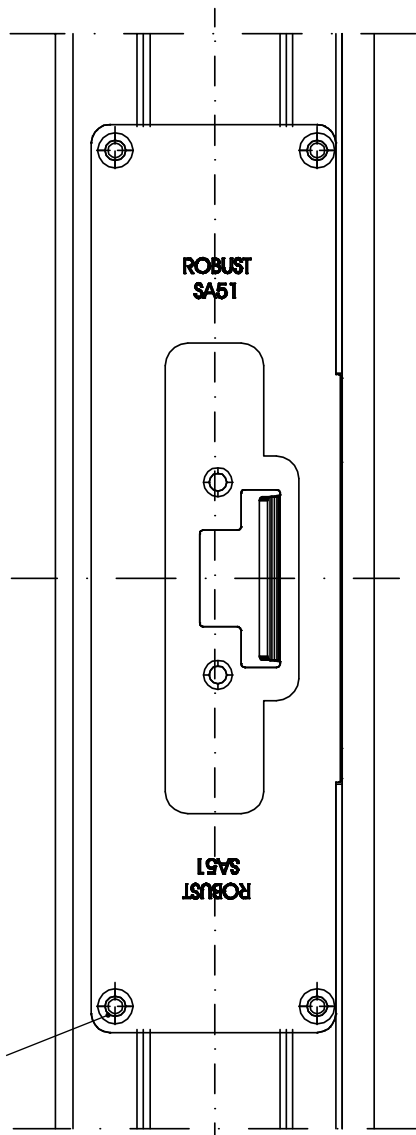

Electric striking plate and face plate as follows:
 Robust 200 + face plate T52
 Robust 100 and 300 + face plate
 SA51 and SB511

Screw (x4)
 P/N 12134

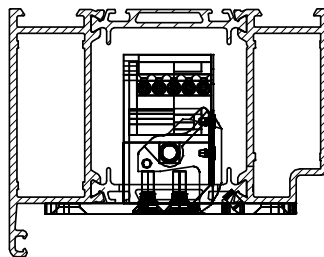

NB! Fastening screws are included in delivery.

Door closer/automatics assembling:

- A**= Mounting on hinge side (overhead from installation)
- B**= Mounting on hinge side (standard installation)
- C**= Mounting on hinge-opposite side (overhead frame installation)
- D**= Mounting on hinge-opposite side (standard installation)

Examples provided above refer both for outward opening door and for inward opening door.

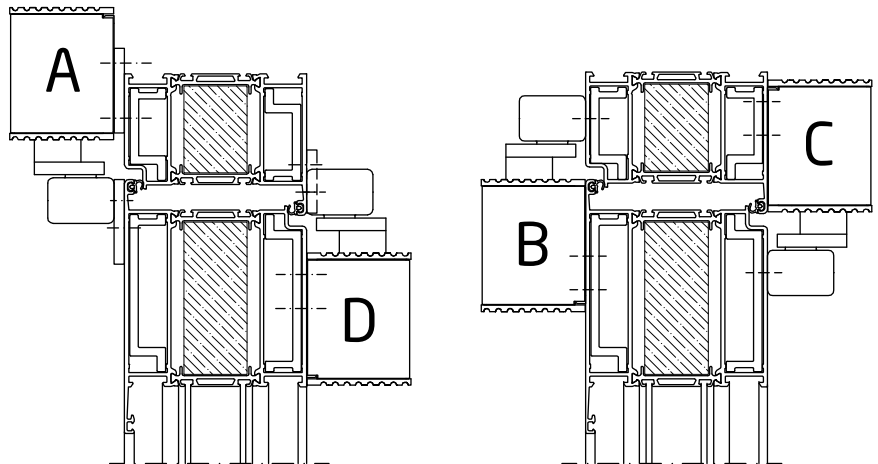

- A**= Mounting on hinge side
- C**= Mounting on hinge-opposite side

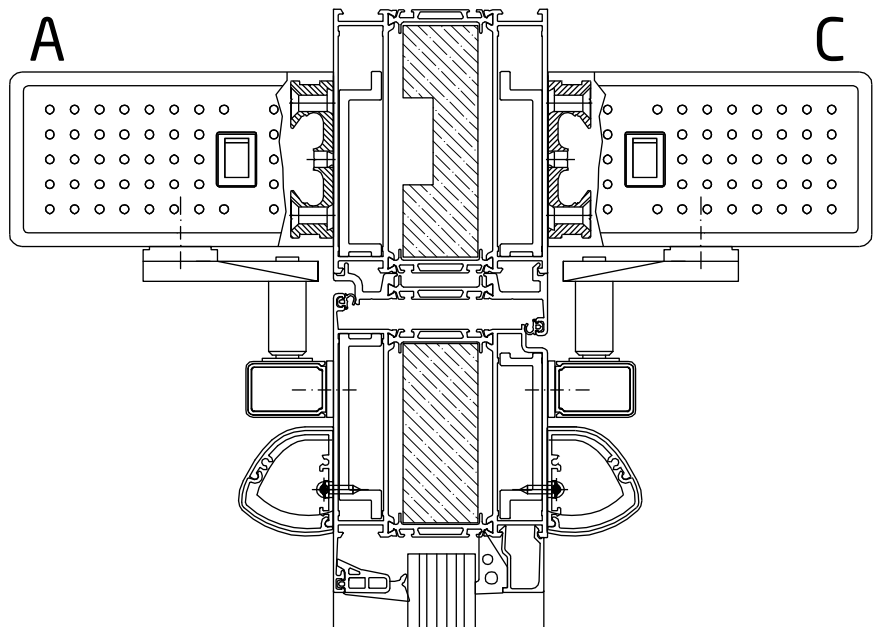

NB! Fire doors must always be equipped with a connected door closer (alt. an automatic door operation). All automatics are only approved in combination with a lock latch.

Anti-panic fittings assembling:

- A.** The device at locking side of the primary door is attached according to the supplier's instructions. At the hinge side: device is mounted with screws, P/N 12709 (x4), through both section walls.
- B.** The device on the slave door is attached with screws P/N 12709 (x4). Similar principle for top, center and bottom installation.
- C.** At the bottom: device of the slave door is locked to the striking plate, ASSA A92. The striking plate is mounted with steel screws M4 (x3).
- D.** At the top: device of the primary door is locked to the striking plate, ASSA A96, in door frame. The striking plate is mounted with screws P/N 12710 (x3). A spacer of approx. 5.5 mm is used to adjust height to a striking plate.

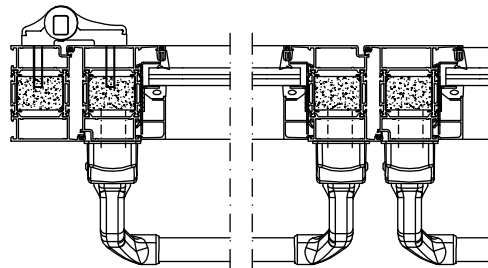
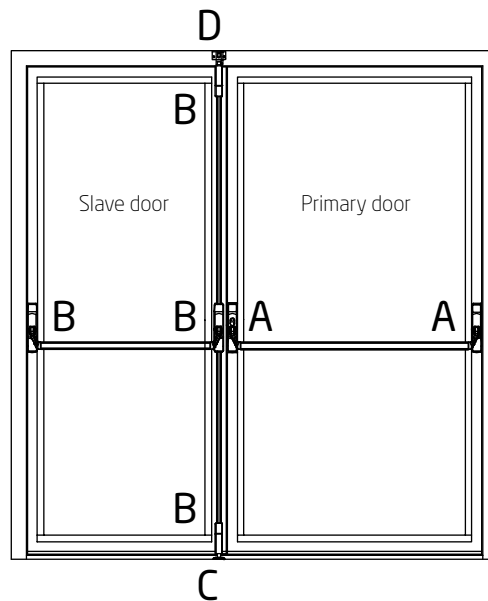

NB! Example above refers to ASSA 1130 and 1130:1 but similar assembly procedure is recommended for other panic exit devices. Only screws are included in delivery.

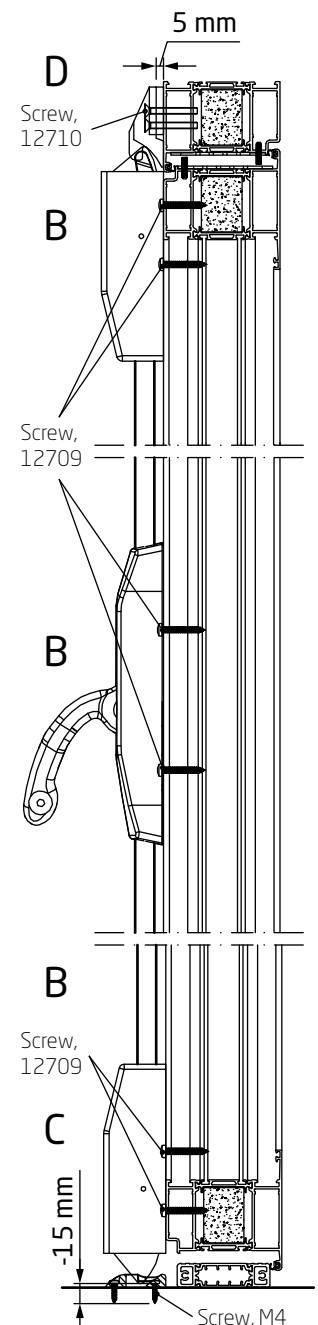

Cylinders and handles assembling:

External side between cylinder accessories, handle and door leaf must be sealed with sealing compound P/N 12222 (this applies to external constructions only).

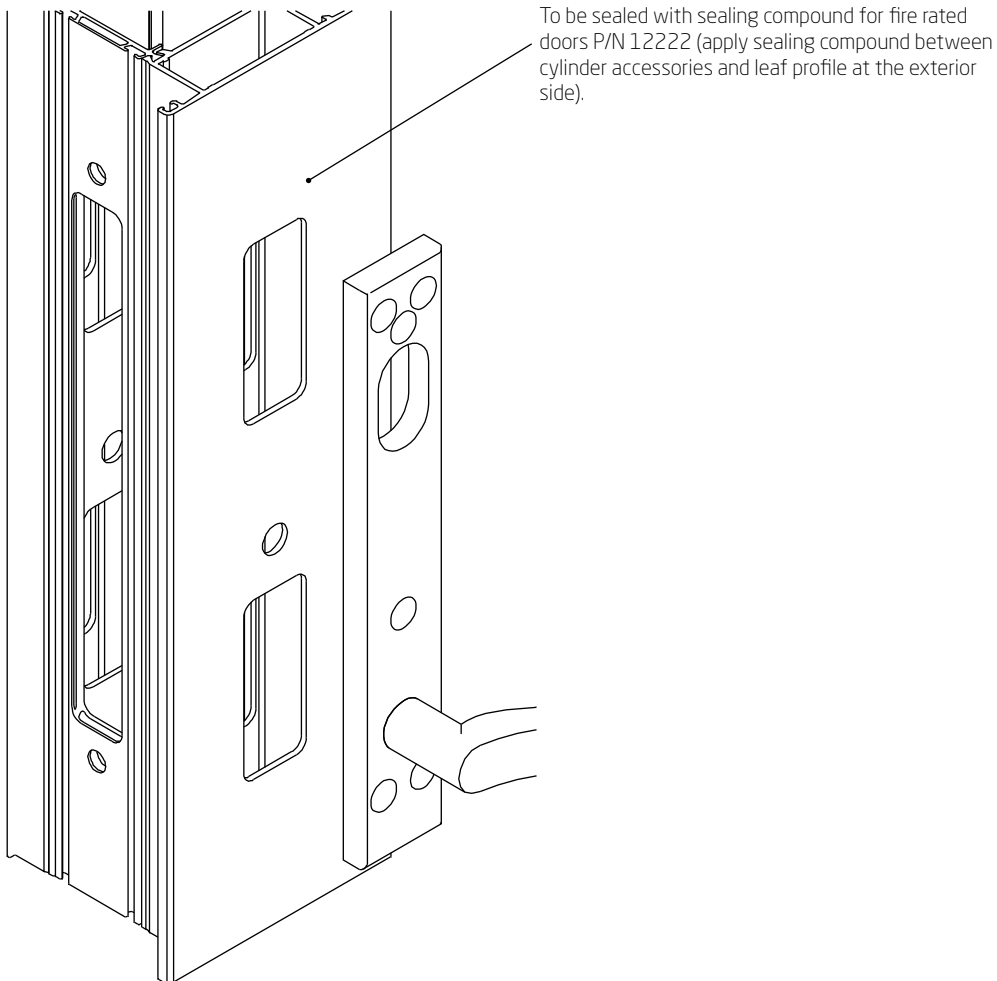

NB! Only metal cylinder accessories and handles are approved for use in fire resistant doors.

Finger trap protection Athmer Fingerschutz BA-28 assembling on the hinge side

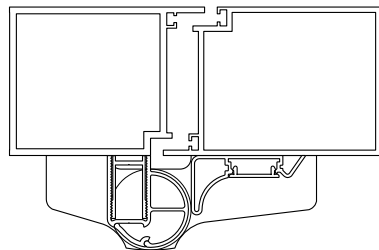
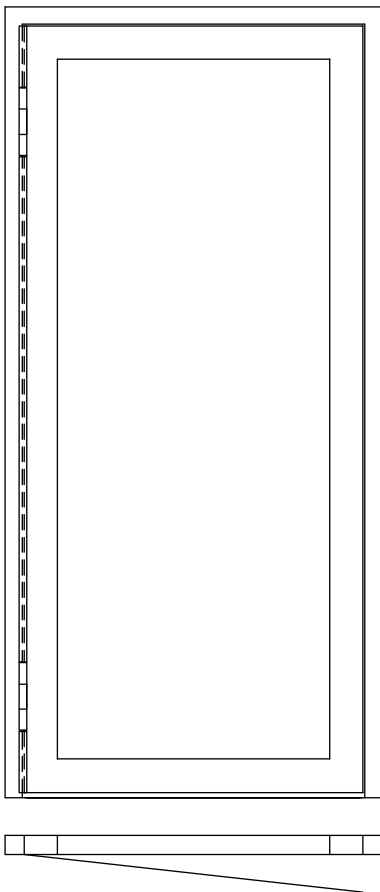

Slim design hinge (14090)

NB! Finger trap protection is compatible with slim design hinges (14090)! Protection must be mounted with screws P/N 12138.

We recommend ordering factory-installed finger trap protection. If installation will be conducted on site, follow installation guides provided by the manufacturer of finger trap protection (included with delivery).

Finger trap protection Athmer Fingerschutz NR-32 assembling on the hinge-opposite

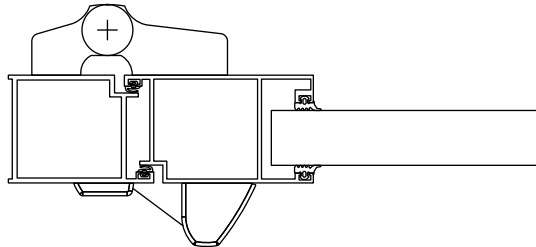
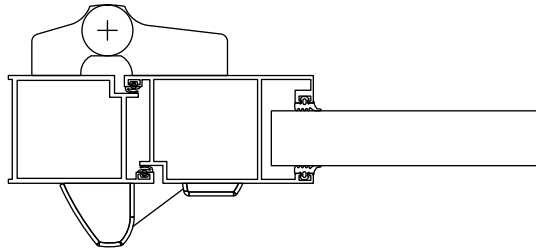
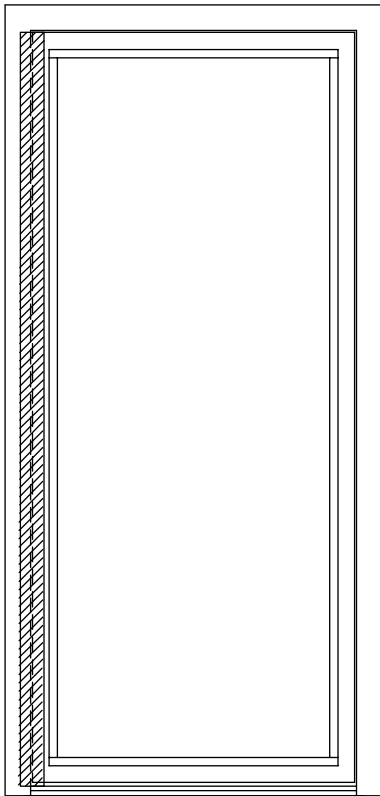

NB! Protection must be mounted with screws P/N 12163.

We recommend ordering factory-installed finger trap protection. If installation will be conducted on site, follow installation guides provided by the manufacturer of finger trap protection (included with delivery).

When finger trap protection is factory-mounted and installation with Adjufix is foreseen, installation of the protection system must be completed once the product is installed into the opening.

Factory installed protection.

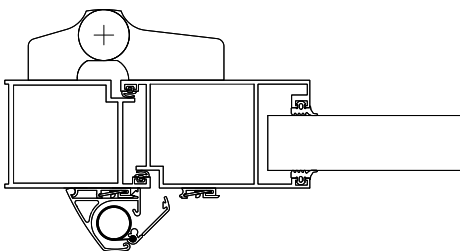

Elements of finger trap protection must be joined once the door is installed.

